

LABORATORIES FOR THE 21ST CENTURY: CASE STUDIES

Case Study Index

Laboratory Type

- Wet lab
- Dry lab
- Clean room

Construction Type

- New
- Retrofit

Type of Operation

- Research/development
- Manufacturing
- Teaching
- Chemistry
- Biology
- Electronics

Service Option

- Suspended ceiling
- Utility service corridor
- Interstitial space

Featured Technologies

- Fume hoods
- Controls
- Mechanical systems
- Electrical loads
- Water conservation
- Renewables
- Sustainable design/planning
- On-site generation
- Daylighting
- Building commissioning

Other Topics

- Diversity factor
- Carbon trading
- Selling concepts to stakeholders
- Design process

LEED Rating

- Platinum
- Gold
- Silver
- Certified



Steve Hall, Hedrick-Blessing/PIX12656

NIDUS CENTER FOR SCIENTIFIC ENTERPRISE, ST. LOUIS, MISSOURI

Introduction

The Nidus Center for Scientific Enterprise makes excellent use of energy recovery and other design features that help to save a considerable amount of energy. This center, a pioneer in the certification process for energy-efficient buildings, is a not-for-profit plant biotechnology and life sciences incubator in St. Louis, Missouri, sponsored by the Monsanto Company. It provides support services, technical and business advice, and reasonably priced office and laboratory facilities to local start-up companies that commercialize promising new ideas. The center also helps to draw researchers and entrepreneurs to the region and to retain others, such as those who attend local universities and work at the Danforth Plant Science Center, Monsanto, and other nearby firms.



U.S. Department of Energy
Energy Efficiency and Renewable Energy
Federal Energy Management Program



The Nidus Center has many sustainable, high-performance features. They include a flexible layout, self-sustaining landscaping, extensive use of daylighting, an efficient mechanical system with energy recovery, and water conservation. Local materials were used extensively, as well as materials containing low amounts of volatile organic compounds (VOCs) and those with a high recycled content.

For all its sustainable features, the Nidus Center received a silver rating through the U.S. Green Buildings Council (USGBC) Leadership in Energy and Environmental Design (LEED) certification system, Version 1.0. The facility was involved in pilot projects testing the certification process and was one of the first 12 buildings to receive LEED certification. It was the first LEED-certified lab.

This case study is one in a series produced by *Laboratories for the 21st Century*, a joint program of the U.S. Environmental Protection Agency (EPA) and the U.S. Department of Energy (DOE). It is geared toward architects and engineers who are familiar with laboratory buildings. The program encourages the design, construction, and operation of safe, sustainable, high-performance laboratories.

Project Description

The Nidus Center is a two-story, 41,233 gross ft² (22,554 net ft²) laboratory and office building on the

northeast corner of Monsanto's 210-acre corporate campus in St. Louis. It was completed in the fall of 1999 at a cost of \$10.2 million for the building, interiors, and site work (\$247/gross ft²). It was designed by the architectural firm of Hellmuth, Obata + Kassabaum, Inc. (HOK). The structural and civil engineers were EDM, Inc.; William Tao & Associates were the mechanical, electrical, and plumbing engineers. The general contractor was the Paric Corporation.

The center serves entrepreneurial clients who are researching, refining, and preparing plant and life science technologies for the marketplace. The facility offers wet and dry lab space as well as office space for approximately 8 to 10 companies. It is designed to accommodate 24 wet/dry laboratories and 22 private offices. It also includes conference rooms, a work room for support services, and a large break area that adjoins a plant-filled atrium. The Nidus Center offers important services for start-up companies, such as business planning and negotiation assistance, mentoring, and access to sources of venture capital. A network of professionals is also available to serve as advisory board members or temporary management.

Layout and Design

The Nidus Center building is oriented along an east-west axis; the long sides face north and south to take advantage of natural lighting. A central hall runs along the spine of the building. Labs are laid out in modules 11 ft

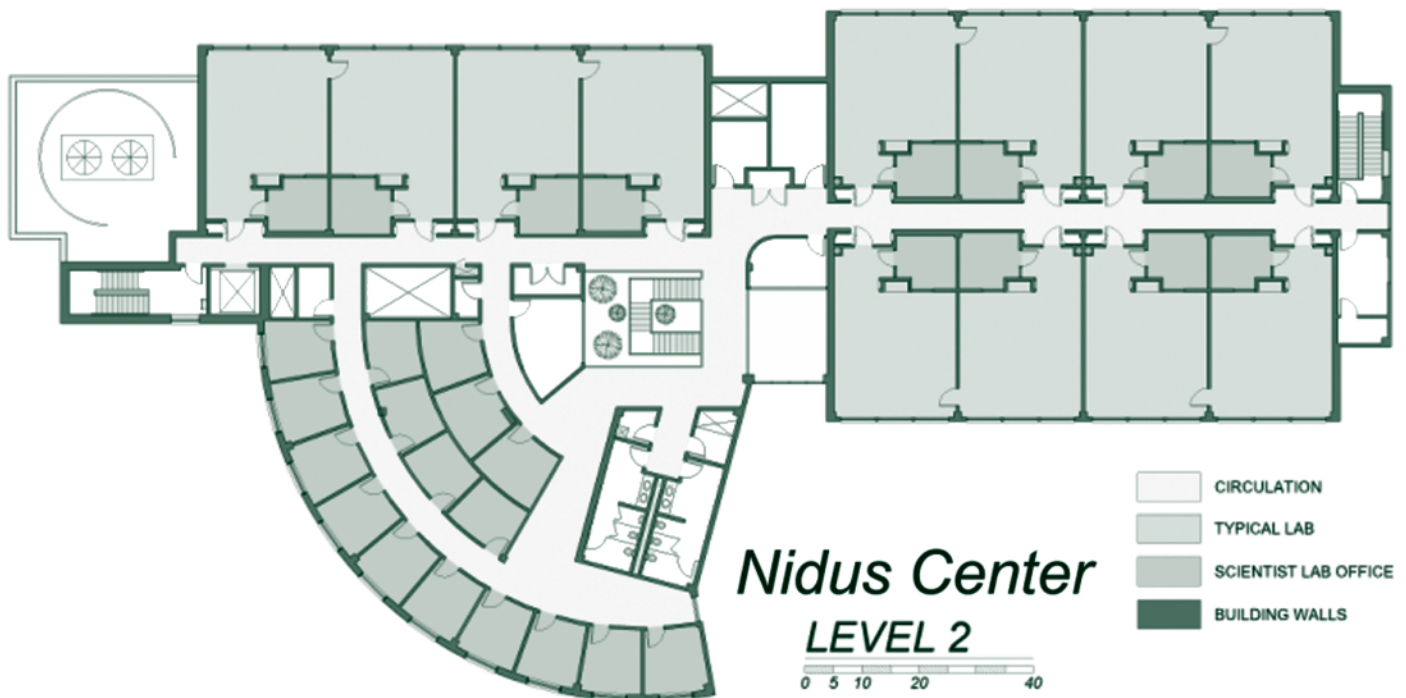

Figure 1. Floor plan of the building (courtesy of HOK Architects)

wide by 33 ft long, and each laboratory is composed of two modules. Each laboratory also has one enclosed office with a large window that looks into the lab, and each lab has a gas storage room.

Every laboratory faces either north or south, with windows that take advantage of daylighting while providing a view to the outside. All the windows on the south side include interior light shelves to reflect light into the labs and exterior sun shades/overhangs. Offices for scientists, building administrative functions, and building functional support are on both floors along a curved wall on the south side of the building. The floor plan for Level 2 is shown in Figure 1.

The building has a large, two-story interior atrium adjacent to a naturally lit coffee bar/break area with an adjacent outdoor shaded patio, as shown in Figure 2. In the two-story spaces, angled and perforated metal exterior sun shades block direct sunlight, but permit views of the sky through the perforations.

A curved stone wall evokes the agricultural image of the old stone barns of rural Missouri. Many details were incorporated into the building to reflect the type of agricultural and plant science research carried out in the facility. For example, corrugated galvanized metal is used as an interior accent finish, as an exterior finish material around the inset windows, and for rainwater-collecting cisterns. Agricultural items such as weathervanes and watering cans are artfully integrated into building’s signage; some signs were even designed to look like seed packages. A view of the exterior showing the cisterns and exterior overhangs for daylighting is shown in Figure 3.

The center’s 24 laboratories were designed to accommodate one fume hood each, although currently only 10 labs use fume hoods. The building was designed primarily to be a Biosafety Level 2 (BL-2) laboratory. BL-2 labs are suitable for work involving agents of moderate potential hazard to people and their environments.

Utility Servicing

Utilities run horizontally in the space above the ceilings on both floors. The main air supply for the building runs above the central hallway. The general exhaust ducts run parallel to the supply air on both sides, in about the middle of the labs. The fume hood exhaust runs parallel in the horizontal ceiling space adjacent to the windows. Boilers, chillers, air handlers, and 8-ft-high heat recovery wheels are all in the building’s basement. Industrial hot and cold water, vacuum, natural gas, and potable hot and cold water are piped through the ceiling to each lab bench. There is a central reverse-osmosis deionized water system



Steve Hall, Hedrick-Blessing/PIX12814



Figure 2. The Nidus Center’s break room opens onto an outdoor patio.

Table 1. Nidus Center Space Breakdown

(In net ft², unless otherwise noted)

Function	Size (net ft ²)	Percentage of Total Space (1)
Labs	13,562	60%
Lab support	865	4%
Scientists’ lab offices	4,787	21%
Administrative offices	1,270	6%
Building functional support	2,073	9%
Total net ft ²	22,554	100%
Other (2)	18,679	
Total gross ft ²	41,233	

Notes:

1. The percentage is a breakdown of the net ft² only; net ft² equals gross ft² minus “other.”
2. “Other” includes circulation, toilets, stairs, elevator shafts, mechanical and electrical rooms and shafts, and structural elements like columns; the net-to-gross-ft² ratio is 0.55.



Steve Hall, Hedrick-Blessing/PIX12657

Figure 3. Exterior view of the Nidus Center shows the cisterns that store rainwater for irrigation and the exterior overhangs.

for the labs and a centralized glass wash and autoclave capability.

Design Approach

A goal for the facility was to be designated a green building by the USGBC. Because it was one of the first LEED projects, the building's owner, designers and contractors faced some challenges associated with pilot-testing the newly designed LEED Version 1.0 certification process. Several of the LEED credits—such as the need to develop a construction waste management plan—required the general contractor to develop new ways of doing business. During the design process, the team members used such tools as collaborative decision-making, design charrettes, and energy simulation modeling. The facility was successfully designed and built in 18 months.

Technologies Used

One major site consideration was the landscape design. It introduced native plantings rich in color and texture, such as native river birch, cinnamon fern, flowering dogwood, and moonbeam coreopsis. No in-ground irrigation system is needed, however. Reclaimed rainwater from the roof is stored in cisterns to irrigate the plants and grass.

Shower facilities in the building help to promote alternative modes of transportation, such as bicycling. Part of the site was once a parking lot. Now, however, specially designated parking spaces are near building entrances to promote carpooling.

Daylighting and Lighting

The building was designed to allow daylight in all lab suites and public areas. Each tenant can make use of large windows on both the north and south sides of the building. The windows on the south side are divided into two sections. The lower section has tinted glass and exterior sun shades to help reduce the impact of low-angle sunlight. An internal horizontal overhang that also functions as a light shelf allows light to penetrate deeper into the building. The north windows, though large, do not need tinted glass or overhangs for shading because of their orientation.

The design of the interior ceiling in the labs helps to make the daylighting more efficient. It is highest, at 12 ft, along the north and south perimeter, and it slopes toward the center of the space to a 9-ft-high ceiling. This design also eliminates dark spots near the center of the ceiling. The strategies all work together to maximize daylight in the spaces. Figure 4 is a view inside a typical laboratory.

Public spaces in the building are naturally daylit by an internal atrium with a skylight. Because of the atrium, the connecting stair, coffee bar/break room, conference rooms, corridors, and lobby are bathed in light. Hallways include windows with views at each end. Windows in the enclosed offices within the labs “borrow” the light in each lab suite.

The connected lighting load is 1.4 W/gross ft². The electric lighting in each lab is controlled with multiple switches to allow users to adjust artificial lighting, as needed. The switching involves two levels in two zones. Lighting in corridors is controlled with wall switches so individual corridors can be switched off when a wing of the building is unoccupied. Lighting in the atrium is controlled with photocells and time clocks, to save energy.

Heating, Ventilation, and Air-Conditioning

The Nidus Center uses one integrated mechanical system with energy recovery for labs and offices. The system keeps general exhaust from the labs separate from fume hood exhaust. Make-up air for the offices is 100% outside air. It first cascades through the offices and then flows through the labs.

According to the mechanical engineer, the enthalpy wheels recover 80% of the heating and cooling energy from this exhaust air stream and transfer it to the make-up air stream. This is the energy equivalent of recirculating



Steve Hall, Hedrick-Blessing/PIX12660

integrated system uses two air-handling units for both lab and office areas, providing one fewer unit than conventional systems, which have one air handler per office area and two per lab area. The resulting savings in equipment and space, in comparison to the cost of a conventional air-handling system, were estimated at more than \$100,000. In addition, the energy recovery wheels reduced both heating and cooling loads, allowing smaller chillers, boilers, pumps, and piping systems to be used. These smaller components saved more than \$210,000; therefore, total first-cost savings were about \$310,000.

The amount of electricity needed for cooling, gas for heating, and power for utility distribution were all reduced by this system. A DOE-2 computer simulation analysis showed that the Nidus Center would consume about 38% less

Figure 4. Inside view of a typical laboratory

energy than a conventional building would, resulting in annual energy cost savings of \$60,000 at current rates. This level of savings was confirmed in an examination of two years' worth of utility bills.

An integrated HVAC system also provides flexibility. Since labs and offices are on the same system, it is easier to change from wet labs to dry labs, from labs to offices, and from offices to labs over the life of the building. The key is a single, integrated system serving both labs and offices from the same main ducts. Conversion can be accomplished locally by modifying boxes and room

80% of the general exhaust without the potential hazards associated with actual recirculation. The use of 100% outside air in the offices results in a quantity of ventilation air greater than that required by ASHRAE standard 62-89. Labs have the 100% outside air required for safety. The diagram in Figure 5 depicts the integrated system.

Fume hood exhaust is discharged in a dedicated exhaust system. The labs use 10 air changes per hour, as specified by the building owner. The fume hoods and general supply and exhaust air system have variable-air-volume (VAV) controls. The fume hoods all have a zone presence sensor that sets back the face velocity from 100 ft per minute (fpm) to 60 fpm when the lab is not occupied.

The two exhaust stacks have integral fans and outside dampers to entrain outside air and substantially dilute the exhaust stream. According to the manufacturer, the exhaust nozzle design enhances flow and pressure to increase outlet velocities while minimizing horsepower requirements.

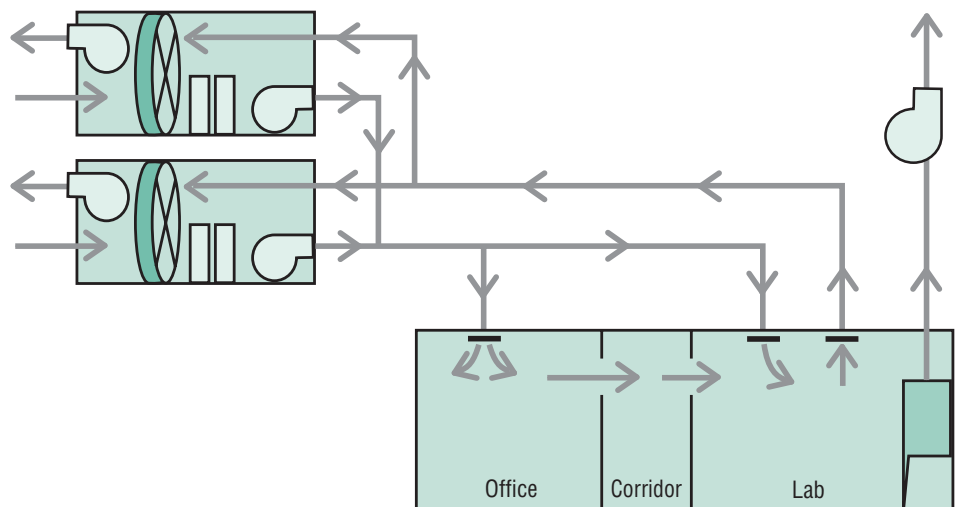

Figure 5. Diagram of the Nidus Center's mechanical system



ductwork to deliver more or less air, as needed, for the new function.

Materials

The design team specified regionally manufactured brick and metal roofing. The earth fill, concrete, concrete masonry unit (CMU) block, steel, drywall, doors, and window blinds were also available locally. Overall, more than 60% of the materials used in constructing the building were acquired within a 300-mile radius, and more than 50% of the materials contain significant recycled content.

All the interior materials—including paint, adhesives, and finishes—are low in VOCs. The waste management subcontractor separates materials and provides recycling off site. Asphalt, concrete, metals, cardboard, and plastics were all recycled.

Indoor Environmental Quality

Indoor air quality is enhanced by using 100% outside air in the offices. It is also enhanced by a living wall of indoor plants in the atrium, which provides natural air filtration.

Table 2. Nidus Center Metrics

System	Key Design Parameters	Annual Energy Use (based on design data)	Annual Energy Use (based on utility bills)
Ventilation (Sum of wattage of all the supply and exhaust fans)	Supply = 1.15 W/cfm Exhaust = 0.73 W/cfm Average = 0.93 W/cfm (1) 2.6 cfm/net ft ² (2)	30 kWh/gross ft ² (42.4 kWh/net ft ²) (3)	29.6 kWh/gross ft ² for the sum of ventilation and cooling
Cooling Plant	350 tons (2 @175 tons each) 0.61 kW/ton	15 kWh/gross ft ² (4)	See ventilation
Lighting	1.4 W/gross ft ²	6.3 kWh/gross ft ² (5)	See process/plug
Process/Plug	8 W/net ft ²	18.5 kWh/gross ft ² (6)	14.6 kWh/ gross ft ² /yr for the sum of plug and lights
Heating Plant	3,024 MBH (2 boilers at 1512 each; 1 MBH is the equivalent of 1000 Btu/hr)	65 kBtu/gross ft ² /yr (7)	147.3 kBtu/gross ft ² /yr
Total		69.8 kWh/gross ft ² /yr for electricity only (238 kBtu/gross ft ² /yr for electricity only)	44.2 kWh/gross ft ² /yr for 2002 electricity only (151 kBtu/gross ft ² /yr for electricity only) (8)
		Total estimated energy use = 301 kBtu/gross ft ² /yr	Total energy usage in 2002 = 298 kBtu/gross ft ²
			Actual annual cost for electricity and gas equals \$2.15/gross ft ² /yr (based on 2002 utility bills)

Notes:

1. W/cfm for supply air = 52,000 cfm ÷ 30 kW = 1.15 W/cfm; for exhaust air = 58,200 cfm ÷ 42.6 kW = 0.73 W/cfm; average = (1.15 W/cfm + 0.73 W/cfm)/2 = 0.93 W/cfm.
2. 58,200 cfm (exhaust) ÷ 22,554 net ft² = 2.6 cfm/net ft² (1.4 cfm/gross ft²).
3. 0.93 W/cfm x 1.41 cfm/gross ft² x 8760 hours x 2/1000 = 29.9 kWh/gross ft² (42.4 kWh/net ft²).
4. 0.61 kW/ton x 350 tons x 2890 hours / 41,233 gross ft² = 14.96 kWh/gross ft² (assumes cooling runs 33% of the hours in a year).
5. 1.4 W/gross ft² x 4534 hours /1000 = 6.34 kWh/gross ft² (assumes lights are on 87.2 hrs/week).
6. 4.4 W/gross ft² x 0.80 x 5256 hours/1000 = 18.5 kWh/gross ft² (8 W/net ft² x 0.55 = 4.4 W/gross ft²) (assumes that 80% of all equipment is operating 60% of the hours in a year).
7. The simulation estimates heating energy at 65 kBtu/gross ft²/yr.
8. Total electric use for the building in 2002 equaled 1,832,216 kWh. July was the peak demand month in 2002, at 412 kW. Natural gas use equaled 607 therms.

Note: Estimated data are presented in site Btu (1 kWh = 3412 Btu). To convert to source Btu, multiply site Btu for electricity by 3. St Louis has approx. 4,758 heating degree-days and 1,534 cooling degree-days).

Water Efficiency

Above-ground galvanized metal cisterns collect rainwater from the roof and store it for irrigation. This system saves water and associated pumping energy while reducing the load on drainage and storm-water systems. The plumbing fixtures use 20% less water than that specified in the water usage requirements of the Energy Policy Act of 1992. The plumbing fixtures used include 1.6-gallons-per-flush (gpf) toilets and 1-gpf urinals. The contractor then adjusted the flows to 1.3 and 0.7 gpf, respectively. Low-flow faucets and showers were also specified. The cooling towers were designed to reduce drift and evaporation.

Measurement and Evaluation Approach

The building manager monitors and tracks energy bills to determine cost savings. The general contractor performed the commissioning for the building to ensure system performance.

Building Metrics

Table 2 summarizes the building's metrics and compares the total annual estimated energy use to the actual use shown in the energy bills. Actual measured energy use, based on the two years' worth of energy bills, averaged 322 kBtu/ft²/yr. The data reported in Table 2 are for 2002 only, when energy use was slightly lower at 298 kBtu/ft²/yr.

Metered data show electrical use in two categories: (1) process/plug and lighting loads, and (2) ventilation and cooling loads. The process/plug and lighting loads account for 33% of the total electrical load, while ventilation and cooling account for 66%.

The 38% savings represents the difference between the ASHRAE 90.1 base case building, which was simulated at 517 kBtu/ft²/yr, and the two-year actual usage, 322 kBtu/ft²/yr. The building's actual total energy use over two years was about 6% less than the 347 kBtu/gross ft²/yr predicted by the simulation model. Annual energy use data shown in the middle column of Table 2 are based on estimates from the design parameters rather than the simulation model except for heating energy, which was taken from the simulation. The estimates in the table for electrical uses are higher than the actual performance. The estimate for heating is lower than actual performance.

Summary

The Nidus Center achieved a silver LEED rating for its energy-efficient, green design. Because this was one of the first pilot projects for LEED, the design team played an important role in crafting the LEED methodology. The building design process involved several highly effective elements, such as an integrated team, collaborative decision-making, and design charrettes.

The design itself incorporates many energy-efficient, sustainable design practices. The form and orientation of the building—along an east-west axis with the long sides facing north and south—were optimal for daylighting. The daylighting system incorporates windows for views, apertures for daylighting, internal and external light shelves on the south side, and a sloped ceiling. The mechanical system uses VAV controls on the fume hoods and supply and exhaust air as well as an energy recovery system. The building has rainwater cisterns to retain water for irrigating the site and incorporates recycled and local materials.

Energy use in the building is as designed—approximately 38% better than a conventional laboratory building designed to the ASHRAE 90.1-1989 standard. Actual metered data for the building demonstrate these energy savings.

Acknowledgements

This case study would not have been possible without the contributions of Kelly Jobe, Bill Odell, Robert Barringer, and David Chassin of HOK Architects; Richard Janis of William Tao & Associates, Consulting Engineers; and David Broughton of the Nidus Center. The case study was written by Nancy Carlisle and Otto Van Geet of the National Renewable Energy Laboratory (NREL). Paula Pitchford, editor, and Susan Sczepanski, graphic designer, NREL, also contributed to this case study.





For More Information

On the Nidus Center:

David L. Broughton
Executive Vice President and Chief Operating
Officer
893 North Warson Road
St. Louis, MO 63141
314-812-8002
david.l.broughton@niduscenter.com

David Chassin, A.I.A.
HOK Architects
271 North Broadway, 6th Floor
St. Louis, MO 63102
314-754-4308
david.chassin@HOK.com

Rich Janis, P.E.
William Tao & Associates, Inc.
349 Marshall Ave., Suite 200
St. Louis, MO 63119
314-961-5258
rrjanis@primary.net

On Laboratories for the 21st Century:

Phil Wirdzek
U.S. Environmental Protection Agency
1200 Pennsylvania Ave., N.W.
Washington, DC 20460
202-564-2094
wirdzek.phil@epamail.epa.gov

Will Lintner, P.E.
U.S. Department of Energy
Federal Energy Management Program
1000 Independence Ave., S.W.
Washington, DC 20585
202-586-4858
william.lintner@ee.doe.gov

Nancy Carlisle, A.I.A.
National Renewable Energy Laboratory
1617 Cole Blvd.
Golden, CO 80401
303-384-7509
Nancy_Carlisle@nrel.gov



Laboratories for the 21st Century

U.S. Environmental Protection Agency
Office of Administration and Resources Management
www.epa.gov/labs21century/



In partnership with the
U.S. Department of Energy
Energy Efficiency and Renewable Energy
*Bringing you a prosperous future where energy
is clean, abundant, reliable, and affordable*
www.eere.energy.gov/

Prepared at the
National Renewable Energy Laboratory
A DOE national laboratory

DOE/GO-102003-1772
October 2003

Printed with a renewable-source ink on paper containing at least
50% wastepaper, including 20% postconsumer waste